

ADD+GARDS

COMMERCIAL PRODUCTS

CP400 SPECIFICATION SHEET

PRODUCT SPECIFICATION

APPLICATION

ENVIRONMENT:

Column Protectors filled with air for controlled impact absorption, made from highly flexible, strong, low density polyethylene. Column protectors prevent damage to columns and pillars in warehouses, car parks etc and also to the vehicle or equipment that may have collided with it. They're easy to assemble with no fixings, simply secure with the velcro straps provided. Available in a range of sizes. Stackable for higher protection if required.

ADVISORY SPEED:

3.4km/h for gross weight vehicle of 2500 kg
2.4km/h for gross weight vehicle of 5000 kg

MATERIAL

STRAPS / FIXATIONS:

Linear low density Polyethylene, high visibility UV Resistant- Fire class HB* - non-conductive - impervious to most chemical products.

COLOURS:

Velcro straps – black 50mm x 3080mm
2 black straps to hold 4 sections together.

Yellow

REQUIREMENTS, MAXIMUM PILLAR DIMENSIONS:

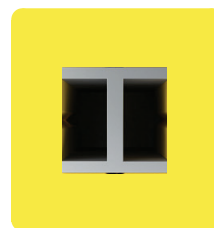

420mm x 420mm

ENVIRONMENT:

Suitable for indoor and outdoor use

WORKING TEMPERATURES:

-15°C up to +40°C

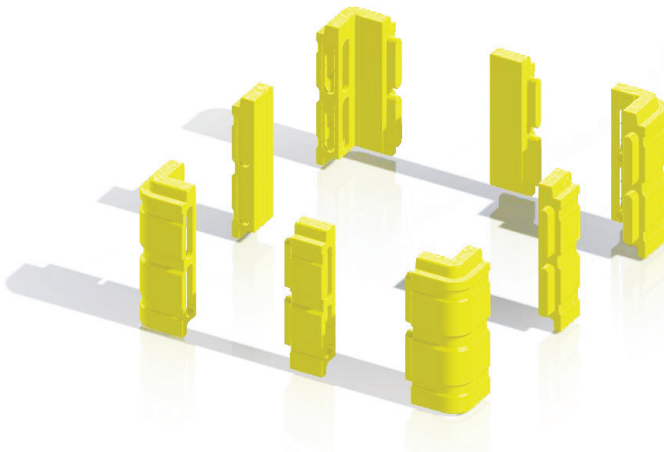
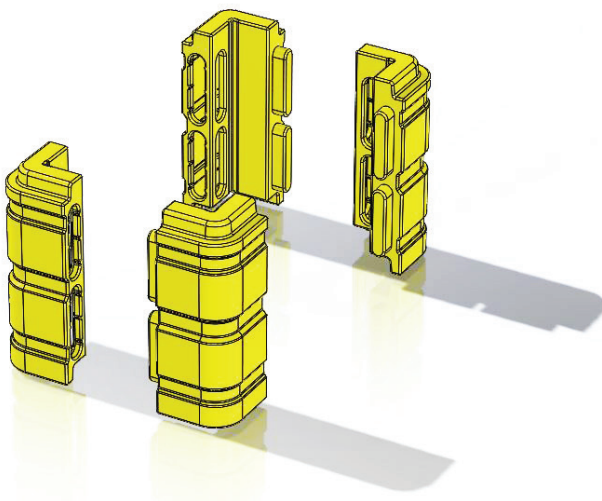

FEATURES AND FUNCTIONALITY

SIZE:		IMPACT PERFORMANCE:		
OUTER DIAMETER:	800mm x 800mm	TEST CONDITIONS:	Ambient temperature	20° Celcius
INNER DIAMETER:	420 x 420mm (extend to 480mm sq with connecting joints)		Forklift Weight	2300kg
WEIGHT:	34kg	90° IMPACT:	Success Criteria	No permanent damage of the protector
HEIGHT:	1.1 Metre		45° IMPACT:	Maximum Impact:
			Maximum Impact:	3100 Joule

CP400 SPECIFICATIONS: (250MM AND 110MM INFILLS CAN BE ADDED TO CP400)

CORNER SECTION:	250mm INFILLS:	110mm INFILLS: